

Wet type Electrostatic Precipitator Technology for Industrial and Power Applications

Chikayuki Nagata, Shiro Suzuki, Kazuaki Miyake, and Kazutaka Tomimatsu

chikayuki_nagata@mhims.mhi.co.jp

shiro2_suzuki@mhims.mhi.co.jp

kazuaki_miyake@mhims.mhi.co.jp

kazutaka1_tomimatsu@mhims.mhi.co.jp

MITSUBISHI HEAVY INDUSTRIES MECHATRONICS SYSTEMS, LTD. (MHI-MS)

1-16, Komatsu-dori 5-chome, Hyogo-ku, Kobe 652-0865 JAPAN

Abstract

Due to the very high performance of Wet type Electrostatic Precipitator (WESP) in collecting particulate matters (PM), it is being widely used in various industrial applications, such as iron & steel plants and boiler plants. In this paper, well-established horizontal flow type WESP technology and newly developed vertical flow type WESP technology of Mitsubishi Heavy Industries Mechatronics Systems (MHI-MS) are introduced.

1. Introduction

Basic mechanism of collecting particulate matter (PM) of Wet type Electrostatic Precipitator (WESP) is the same as that of Dry type Electrostatic Precipitator (DESP), while the collected PM is removed by washing water in WESP, instead of impact force of rapping used in DESP. As WESP uses washing water, it can be applied only in low gas temperature region, such as in water saturate condition, however it has also many advantages such as follows.

- (1) No dust re-entrainment,
- (2) No influence of PM property, such as resistivity, since completely wet surface of PM secures high surface conductivity, and high and stable PM collecting performance is also secured,
- (3) No accumulated PM layer on electrodes, since it is always cleaned by washed water, therefore no performance deterioration occurs due to back corona,
- (4) No moving parts, therefore minimum consumable parts, and
- (5) Compact design can be realized, since higher gas velocity is possible due to no dust re-entrainment, and lower height of hopper is possible, compared with DESP.

Due to such advantages, WESP has already been used in many industrial applications and MHI-MS has delivered more than 300 units in

Japan and other countries, and its application is being expanding.

2. Basic Concept of Horizontal WESP

In accordance with gas flow direction, WESP is roughly classified in horizontal flow type and vertical flow type. MHI-MS have delivered horizontal WESP, for more than fifty years, for many applications, to be reputed in its high performance and high reliability.

The basic construction of the horizontal flow type WESP is similar to that of a conventional dry ESP design as shown in **Figure 1**. Flue gas is introduced horizontally into the WESP casing through an inlet nozzle, in which gas distribution plates are installed. The gas velocity is reduced and uniformly distributed into the main part of the casing, where collecting electrode plates are set in parallel along the gas flow direction. Between

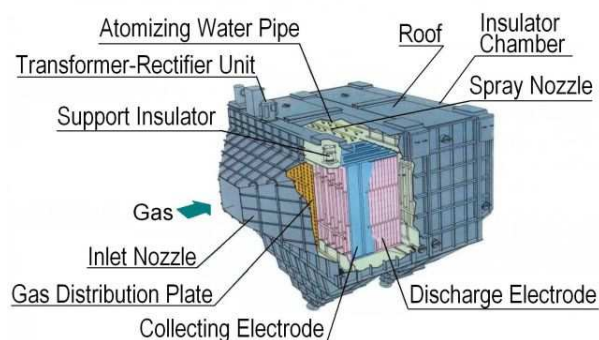

Figure 1 Typical Outline of Horizontal Flow Type WESP

collecting electrode plates, rigid-frame-type discharge electrodes, which have a special geometry with long spikes to maintain high and stable corona discharge currents, are equipped.

PM contained in the flue gas is negatively charged when corona discharge occurs between discharge electrode and collecting electrode, and the charged particles are collected on the collecting electrodes by electrostatic force (Coulomb force).

Depending on the removal efficiency requirement, number of fields of the collecting zone can be selected, and when the requirement for efficiency is very high, it is possible to set electrically independent two or more fields within the same WESP casing to compose multi-field type WESP.

Atomized water is continuously sprayed (under energized condition) into the collecting zone to wash out the PM on the collecting electrode plate. Atomized water droplets are collected easily on electrodes by electrostatic force because of their larger diameter compared with particulate matters contained in the flue gas, and they form water film flow on the collecting electrodes. PM collected by electrostatic force is captured in this water film flow, and washed down. The water flows into a tank below the WESP casing, and discharged to water treatment system of the plant.

If the water supplying condition allows, atomized water can be supplied as “one through” line. In this case, fresh water is atomized from top of WESP. When it is required to save supplying water amount, the atomized water can be re-circulated. In this case, pH of re-circulation water is monitored and it controls the dosing amount of alkaline reagent, such as caustic soda or magnesium hydroxide, put into the re-circulation tank, in order to keep the pH of water always at the optimum value. In order to keep SS (suspended solid) value of atomizing water under certain value, some of the re-circulation water is extracted from auto strainer. Re-circulating water is pumped up to the top of WESP and alkaline water is atomized into the collecting zone of WESP. When the gas includes much acid mist PM, it reduces pH value of water film flow, and it takes the minimum pH value at the bottom, but it must be still kept beyond the

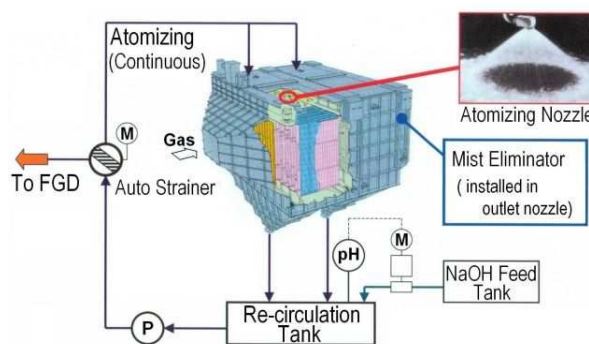

Figure 2 Typical Simplified Process Flow Diagram of Horizontal Flow Type WESP

minimum value in order to avoid acid corrosion.

From the viewpoint of acid corrosion, the most critical region is at dry-wet boundary, and completely wet region is less severe in corrosion, because water covers the metal surface from oxygen included in the air which promotes the oxidation of metal. Continuous atomizing realizes completely wet condition always upon the collecting electrode surface and other metal surface by water film flow, and it allows comparatively cost-effective materials to be used, instead of higher grade alloy materials.

The re-circulation water contains collected PM, and caustic soda, magnesium hydroxide, or their reacted products, so that the outlet gas from the WESP may have carried-over water droplets containing some sodium or magnesium salts. In order to avoid any influence of such carried over reactants on the WESP outlet particulate loading, the outlet side of the last field is atomized by fresh water instead of re-circulation water. When the requirement of WESP outlet PM concentration is extremely severe, mist eliminator can be installed in outlet nozzle. A simplified process flow diagram of the horizontal WESP with typical “re-circulating” atomizing line is shown in **Figure 2**.

3. Horizontal Flow type WESP Applied in Iron & Steel Industry

Horizontal flow type WESP has been so far applied in various processes of iron and steel industry. They are roughly classified into :

- (1) Application for various room gas: such as hot scarfing machine, cold scarfing machine, rolling mill, continuous casting

Table 1 Commercially Operated WESPs Applied in GTCC Plant Using BFG as Fuel

Plant	Delivery Year	No. of WESP Units	Gas Vol. per Unit (m ³ N/h)	Country	Remarks
1	1965	2	61,000	Japan	
2	1982	1	89,000	Japan	
3	1987	1	269,000	Japan	
4	1989	1	162,000	Japan	
5	1990	1	93,000	Japan	
6	1991	1	75,310	Japan	
7	1994	1	310,000	Japan	
8	1995	1	310,000	Japan	
9	1996	1	373,000	China	
10	1996	1	308,000	Netherlands	
11	2000	1	595,000	Japan	
12	2001	1	173,000	Japan	
13	2004	1	550,000	Japan	
14	2005	1	560,000	China	
15	2005	2	148,000	China	
16	2006	1	307,000	China	
17	2006	1	235,000	South Korea	
18	2006	1	143,000	China	
19	2007	1	278,000	China	
20	2007	2	266,000	China	
21	2007	1	144,000	China	
22	2008	4	289,000	Ukraine	
23	2009	2	143,000	China	
24	2009	1	278,000	China	
25	2010	2	283,000	South Korea	
26	2010	1	308,000	Japan	
27	2011	1	306,000	Japan	
28	2011	1	550,000	Japan	
29	2012	2	284,300	South Korea	
30	2013	1	306,000	Japan	Under Construction
31	2013	1	306,000	Japan	Under Construction
32	2013	2	266,000	China	Under Construction
33	2014	1	308,400	Japan	Contracted
34	2014	1	156,300	Japan	Contracted
Total		44	11,551,610		

machine, coke guide for coke oven, blast furnace casthouse, etc.

(2) Application for fuel gas purification: such as blast furnace gas (BFG) before and after

gas holder and converter gas (LDG) after gas holder.

Recently, in the viewpoint of global environmental protection and reduction of greenhouse gas emission, importance of energy saving has been well recognized, and in iron and steel industry, much attention has been paid to BFG, whose calorie is comparatively low and it has been so far often wasted. Gas Turbine Combined Cycle (GTCC) using BFG as fuel can produce additional electric power, and when BFG is used for such purpose, WESP is required to purify the fuel gas to protect GTCC facility.⁽⁶⁾ ESPs are usually applied to remove PM in flue gas to reduce PM emission discharged to the ambient air, however WESP for GTCC is quite unique because it is applied to the fuel line and contributes to the production of additional power, which is very popular in Japan and several other countries and also should prevail more in the world including developing countries. MHI-

MS's delivery records of this type of WESP are summarized in **Table 1** and simplified flow diagram is shown in **Figure 3**.

Such GTCC plant uses fuel of mainly low

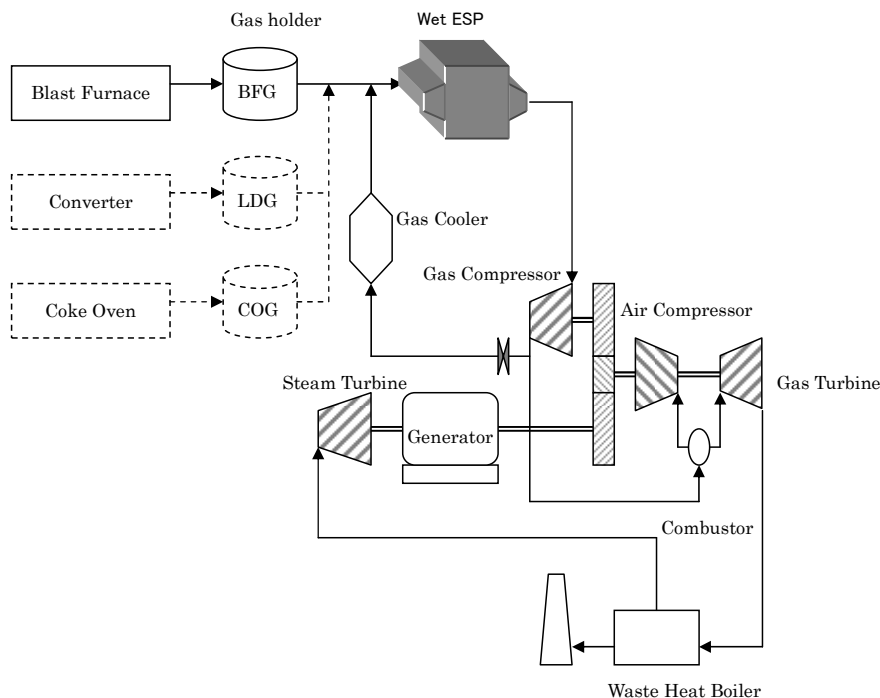

Figure 3 Simplified Flow Diagram of WESP for GTCC Plant Using BFG as Fuel

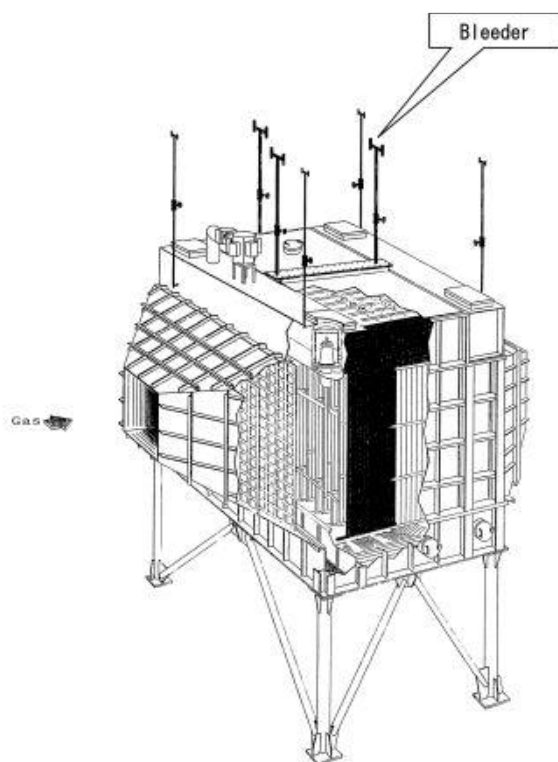

Figure 4 Bleeder Equipped in WESP for GTCC Plant

calorie BFG and sometimes mixed with higher calorie LDG or COG (coke oven gas). The fuel gas contains dust particles of typically 5 to 10 mg/m³N mainly composed of Fe₂O₃, and they are very fine such as less than 1 micron meter. In order to protect gas compressor parts and turbine blades from erosion, the dust concentration must be reduced less than 1 mg/m³N. The fuel gas is in water saturated condition (approximately 30 to 35 deg. C), so that WESP can be applied as the most suitable dust collector.

All BFG, LDG, and COG are toxic and explosive, so that WESP applied for this process must be designed especially to have gas tight construction. At starting up, air

existing in main part of WESP, together with the duct and the main part of gas turbine, is purged by N₂ and after that gas is introduced into WESP in order to protect from gas explosion, and at shut down, gas is purged by N₂ absolutely and after that N₂ must be replaced by air to protect from lack of oxygen in WESP inside during maintenance work. For this purpose, nitrogen injection pipe and air injection pipe for purging, and bleeder, as shown in **Figure 4**, must be equipped. Inlet gas pressure of WESP in this process is typically 400 – 800 mmH₂O, and even more than 2000 mmH₂O is momentary possible in case of emergency shut-down of gas turbine, so that construction design considering such pressure resistance, which is considerably high for WESP, is also required.

MHI-MS's first delivery of WESP for this process was in 1982, and since then, we have already delivered 38 units of this type of WESP and also 6 units are under construction or designing, including 24 units are exporting jobs delivered outside of Japan. Photographs of WESP delivered in Netherlands (**Figure 5**), China (**Figure 6**), and Korea (**Figure 7**) are shown for reference. Stable and high performance has been realized in these references in accordance with MHI-MS's continuous atomizing system under energized condition.

4. Horizontal Flow Type WESP Applied in Boiler of Power Station and Other Sources (Equipped at Downstream of Wet Type FGD)

In the viewpoint of global environmental conservation, requirement for reduction of PM emitted from stationary source becomes more and more strong. For example, so-called MATS (Mercury and Toxics Standards) rule, which is



Figure 5 WESP for GTCC Plant in Netherlands



Figure 6 WESP for GTCC Plant in China



Figure 7 WESP for GTCC Plant in Korea

planned to be finalized in March 2013 in the United States, will require to reduce PM emission less than 0.009 lb/MMBtu (approximately 10 – 12 mg/m³N) for newly constructed thermal power station, and 0.03 lb/MMBtu (approximately 30 – 40 mg/m³N) for existing thermal power station, by 2016. Meanwhile in China, twelfth five-year-plan (2011 – 2015) requires PM emission to be reduced to 20 – 30 mg/m³N, depending on the area of the plant installation.

PM_{2.5}, which is particulate matter whose diameter is less than 2.5 micron meters and floating in the atmosphere, causes severe respiratory diseases and harmful for human health, and its concentration is recently increasing significantly in several countries such as China and India. Especially such high concentration of PM_{2.5} due to PM emission in China often flies across the ocean and cross the border of Korea and Japan, and causes global problem, so that the reduction of PM emission at the PM generating source is becoming emergency issue.

At the PM generating source such as thermal power station, dust collector shall be properly equipped in the flue gas treatment system, and dry type dust collector such as DESP is usually installed at downstream of air pre-heater whose gas temperature is in the typical range of 120 – 160 degrees C. When the emission standard becomes more strictly, one of the countermeasure is to upgrade the dry

type dust collector, however it is often difficult to upgrade the existing facility, such like construction of additional field, because of the limitation of the installation area. Recently heat exchangers and wet type FGD (flue gas desulfurization) shall usually be installed in accordance to SO₂ emission standard, and when SO₃ concentration is high, sulfuric acid condensation often causes corrosion problem in heat exchanger, and in order to prevent it, some solid PM proportional to SO₃ amount shall be remained in the flue gas, and in such case PM concentration at outlet of dry type dust collector shall not be reduced too much.

Another countermeasure is to install WESP at downstream of wet type FGD, keeping the original design of dry type dust collector, and WESP can reduce all remaining PM at outlet of wet type FGD. In this case, WESP can reduce not only the PM generated from the source but also other PM carried-over from FGD, such as sulfuric acid mist condensed in FGD caused by SO₃ gas content included in the flue gas and salts from FGD re-circulation water, so that PM emitted from stack can technically be reduced less than 1 mg/m³N, which is almost invisible. Considering the reduction of very fine PM_{2.5} in atmosphere, installing high performance WESP in the last stage of flue gas treatment system is the most effective way. The conceptual flow chart of PM balance in boiler flue gas treatment system with WESP is shown in **Figure 8**.

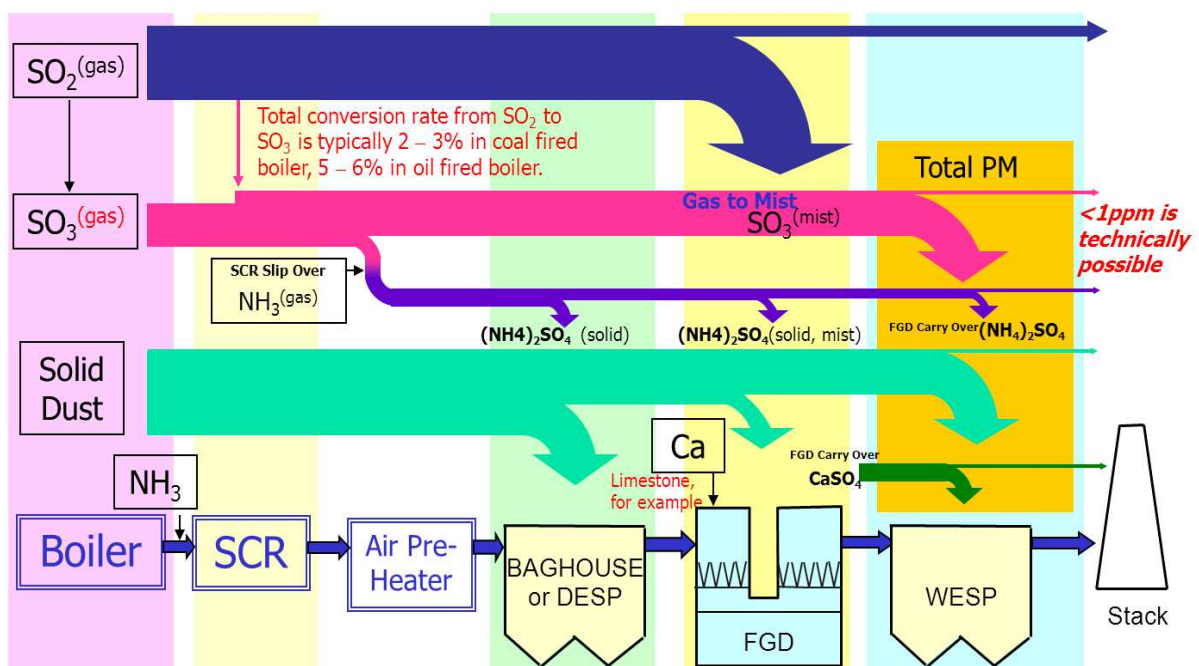

Figure 8 Conceptual Flow Chart of PM Balance in Boiler Flue Gas Treatment System with WESP

Table 2 Commercially Operated WESPs Applied in Boiler of Power Station and Other Sources (Equipped at Downstream of Wet Type FGD)

Plant	Delivery Year	Boiler Fuel or [Source ^(Note 2)]	No. of WESP Units	Gas Vol. per Boiler (m ³ N/h)	Country	Remarks
1	1975	Oil	1	202,000	Japan	
2	1975	Pet Coke	2	260,000	Japan	
3	1977	[Sinter Plant]	1	650,000	Japan	
4	1977	Oil	1	276,000	Japan	
5	1978	[Oil Ash Incinerator]	1	89,000	Japan	
6	1978	Oil	1	500,000	Japan	
7	1981	Oil	1	350,000	Japan	
8	1982	Coal	1	17,000	Japan	Pilot Test Facility
9	1983	Oil	1	550,000	Japan	
10	1985	COM (Coal-Oil Mixture)	1	935,000	Japan	
11	1987	Coal	1	15,000	Japan	Pilot Test Facility
12	1991	Coal	2	2,500,000	Japan	
13	1992	Coal	2	2,500,000	Japan	
14	1992	[FCC]	1	166,000	Japan	
15	1993	Coal	2	2,500,000	Japan	
16	1993	[Sinter Plant]	1	315,000	Japan	
17	1994	[FCC]	1	126,000	Japan	
18	1994	[FCC]	1	200,000	Japan	
19	1996	Oil	1	24,000	Japan	
20	1996	Oil	1	280,000	Japan	
21	1996	Oil	1	524,000	Austria	
22	1998	Residual Oil	1	671,000	Japan	
23	1998	Residual Oil	1	267,500	Japan	
24	2000	[FCC]	1	595,100	Japan	
25	2002	[Sinter Plant]	1	550,000	Japan	
26	2003	Residual Oil	1	782,000	Japan	
27	2004	[Sinter Plant]	1	550,000	Japan	
Total			31	16,394,600		

Note 1 This table summarizes only horizontal WESP, excluding vertical WESP.

Note 2 "[Source]" shows that the flue gas source is not boiler, however WESP is equipped in the flue gas system at downstream of wet type FGD in order to remove fine PM.

- Sinter Plant : Main gas treatment from sinter machine in steel plant
- Oil Ash Incinerator : Gas treatment from incinerator to reduce volume of oil ash generated from oil-fired boiler
- FCC : Gas treatment from FCC (Fluid Catalytic Cracking Process) in oil refinery

MHI-MS is the pioneer of horizontal flow type WESP installed at water saturate region at downstream of wet type FGD as “finishing PM collector”, and its first commercial installation was 1975. Delivery record of this type of WESP is shown in **Table 2**. Reference photographs are shown in **Figure 9** for WESP in 700MW coal-fired boiler plant in Japan⁽¹⁾⁽²⁾, and in **Figure 10** for WESP in oil-fired boiler plant in Austria⁽⁵⁾. **Table 2** shows the references of only horizontal flow type WESP, excluding vertical flow type WESP. Many of them are applied in boiler



Figure 9 WESP for Coal-Fired Boiler in Japan



Figure 10 WESP for Oil-Fired Boiler in Austria

plants, however some of them are applied also at downstream of wet type FGD but for the flue gas treatment system from sources other than boiler, as noted in the table.

In this kind of WESP, very fine PM_{2.5} is included in PM to be treated, and in such case considerations to space charge is necessary⁽³⁾⁽⁴⁾.

Space charge is proportional to the total surface area of particles introduced into WESP per unit time, and namely it becomes large when the gas velocity is high and when particle diameter is small, for the same

concentration of PM. When space charge is high, corona discharge is extremely suppressed (corona quenching) and spark-over voltage is reduced (excessive spark-over), and as a result, WESP performance is significantly reduced.

For example, the diameter of sulfuric acid caused by SO₃ content in flue gas is “sub-micron”, namely in the range of 0.1 – 1 micron meters, and it is obviously classified as PM_{2.5}. **Figure 11** shows the example of measuring result of the diameter of sulfuric acid in the actually operated commercial boiler plant, using DMA (Differential Mobility Analyzer), and in this case the mean diameter of sulfuric acid is 0.075 micron meters in mass basis and 0.3 micron meters in particle number count basis. When such very fine particles are included much in the flue gas, space charge amount becomes very high, and this is the condition given by condition of PM included in the flue gas. Therefore, in order to keep performance

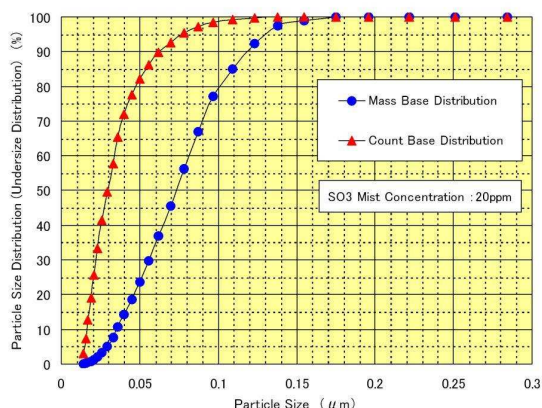

Figure 11 Measuring Result of Diameter of Sulfuric Acid Mist (SO₃ Mist)

of WESP with minimum efficiency reduction even if considering these given conditions, gas velocity should be reduced in order to reduce space charge, however it also means increasing the cost by increased size of WESP, so that to select the most appropriate gas velocity and WESP volume to realize the most effective cost is very important.

MHI-MS's WESP is equipped with continuous atomizing system, and in WESP it realizes to cover the electrode surface with water film flow, which relaxes the corrosion condition even if acid PM like SO₃ is included much in the flue gas, stainless steel of 316L class can be used as material of electrode, and higher grade alloy metal is not necessary to be used. Inside surface of casing can be covered with resin lining to protect from corrosion, and it allows usual carbon steel to be used as the base material of the casing. These design consideration realizes the cost effective WESP.

5. Newly Developed Vertical Flow Type WESP

Horizontal flow type WESP introduced in clause 4 is very effective for the countermeasure to reduce PM_{2.5}, while sometimes vertical flow type WESP is more

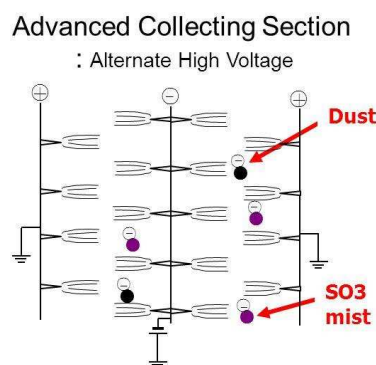

Figure 12 Concept of New Vertical Flow Type WESP

preferable. However, in the case of vertical flow type WESP, counter flow of washing water and gas makes difficult to keep the stable water film flow, and maximum velocity is often limited, so that it also limits the maximum gas volume to be treated, and as a result it is very difficult to design vertical flow type WESP with very large capacity. Moreover, unstable water film flow easily causes spark-over and performance reduction, and the difficulty of continuous washing makes difficulty in protection from corrosion.

MHI-MS has newly developed very unique electrode construction and configuration which enable highly stable vertical flow type WESP with high efficiency⁽⁴⁾, which has been already operated commercially. **Table 3** shows the delivery list of this kind of WESP.

This new vertical flow type WESP adopts alternate high voltage system in collecting zone, to keep high performance. Projections, whose tip will be the corona starting point, are set alternately both on negative electrode plate and on positive electrode plate, so that PM can be collected both on negative electrode plate and positive electrode plate with high volume efficiency. The concept of this new vertical flow type WESP is shown in **Figure 12**. Spray system of washing water with intermittent washing, which enables to keep wet condition

Table 3 Commercially Operated Newly Developed Vertical Flow Type WESP

Plant	Delivery Time	Boiler Fuel or [Source ^(Note)]	No. of WESP Units	Gas Vol. per Boiler (m ³ N/h)	Country	Remarks
1	Dec. 2002	Vacuum Residual Oil	1	320,000	Japan	1 stage
2	Mar. 2003	[FCC]	1	120,000	Japan	1 stage
3	Nov. 2003	Pet Coke	1	160,000	Japan	2 stages
4	Nov. 2003	Pet Coke	1	170,000	Japan	2 stages
Total			4	770,000		

Note 2 "[Source]" shows that the flue gas source is not boiler, however WESP is equipped in the flue gas system at downstream of wet type FGD in order to remove fine PM.

- FCC : Gas treatment from FCC (Fluid Catalytic Cracking Process) in oil refinery

appropriately in spite of the vertical gas flow direction, has also been developed. Reference photograph is shown in **Figure 13**.



Figure 13 Vertical Flow Type WESP in Japan

In the reference shown in **Figure 13**, although flue gas from boiler fueled with VR (Vacuum Residual Oil) contains high concentration of SO_3 and boiler dust, combined with Salt Solution Spray system⁽⁷⁾⁽⁸⁾, very high PM reduction efficiency has been achieved.

This new vertical flow type WESP is investigated to be applied to the system of carbon reduction in flue gas. Commercially operated CCS (Carbon Capture and Storage) plant is highly anticipated to be realized to capture CO_2 , which causes global warmth problem and included much in the flue gas from thermal power station. Regarding the CO_2 capture, chemical absorption method using amine-based absorbent is predominant at this moment. Amine-based absorbent suffers deterioration and loss due to SO_2 and SO_3 in flue gas, and dust in flue gas is accumulated and condensed in re-circulation line of the absorbent. In order to reduce SO_2 , Deep FGD is installed at upstream of CO_2 absorber, and vertical flow type WESP to reduce SO_3 and dust which can be physically combined with Deep FGD is highly anticipated.

MHI-MS has already completed the test in laboratory, in order to apply the new vertical flow type WESP in CCS plant, and its performance property has confirmed, and it is ready to be applied in the actual gas condition.

6. Summary

WESP as PM collector with high performance is expected to be applied in various fields, and MHI-MS's technologies are explained in this paper, such as horizontal flow type WESP to purify BFG gas to be used as fuel of GTCC, as an example of increasing effectiveness of energy use, and also horizontal flow type

WESP to remove fine particles efficiently from flue gas from boiler, etc., as an example of countermeasure of global problem of $\text{PM}_{2.5}$. And newly developed vertical flow type WESP and its possibility to apply in CCS plant is also introduced.

References

1. Fujishima, H. and Tsuchiya, Y., *Application of Wet Type Electrostatic Precipitators for Utilities' Coal-Fired Boiler*, Joint Conference of Tenth Particulate Control Symposium and Fifth International Conference on Electrostatic Precipitation, Washington D.C., USA, April 1993.
2. Fujishima, H. and Tsuchiya, Y., *Application of Wet Type Electrostatic Precipitator for Boiler Plants*, Sixth International Conference on Electrostatic Precipitation, Budapest, Hungary, June 1996.
3. Bärnthaler, K., Guggenberger, W., and Kindlhofer, W., *Design and Start-Up of a Limestone FGD for an Oil Fired Boiler in Werndorf / Austria*, The Mega Symposium, Washington D.C., USA, August 1997.
4. Fujishima, H. and Nagata, C., *Experiences of Wet Type electrostatic Precipitator Successfully Applied for SO_3 Removal in Boilers Using High Sulfur Content Fuel*, Ninth International Conference on Electrostatic Precipitation, Kruger Gate, South Africa, May 2004.
5. Nagata, C., Fujitani, H., and Blythe, Gary M., *Wet Type Electrostatic Precipitator Successfully Applied for SO_3 Mist Removal in Boilers Using High Sulfur Content Fuel*, Combined Power Plant Air Pollutant Mega Symposium, Washington D.C., USA, August 2004.
6. Nagata, C., Miyake, K., and Suzuki, S., *Industrial and Advanced Applications of Wet type Electrostatic Precipitator Technology*, 11th Chinese National Conference on Electrostatic Precipitation, Zhenzou, China, October 2005
7. Nagata, C., Miyake, K., Nagasawa, H., and Noguchi, T., *Experience of Systems to Reduce SO_3 from Flue Gas of Combusting High Sulfur Content Residual Materials in Oil Refinery*, Twelfth International Conference on Electrostatic Precipitation, Nuernberg, Germany, May 2011.
8. Nagata, C., Miyake, K., Nagasawa, H., and Noguchi, T., *Experience of Systems to Reduce SO_3 from Flue Gas of Combusting High Sulfur Content Residual Materials in Oil Refinery*, International Journal of Plasma Environmental Science and Technology, Vol. 5, No. 2, 2011.